

REPLACE (R10) 15M WITH 4" JUMPER (04303)
 REPLACE (R9) 15M WITH 1.74M (03747)

DO NOT PLACE D24 & D25 THROUGH FRONT PANEL

REPLACE (Z2) 4570 WITH DPA2604 (03614)
 REPLACE (R31) 20K WITH 1.74M (03747)
 REPLACE (C8) 22/25 WITH 00047 (00173)

J25-1 (#33) TO J26C AS SHOWN
 SOLDER WIRE FROM J25-1 (#33) TO J26C AS SHOWN
 CUT HEADER PIN J26-1 (#38)

REMOVE S2
 REPLACE R191 WITH 1K (00003)
 REMOVE V23 AND ADD R500 AS SHOWN
 SOLDER WIRE FROM V23/R191 TO R50/Z8-13R14 AS SHOWN

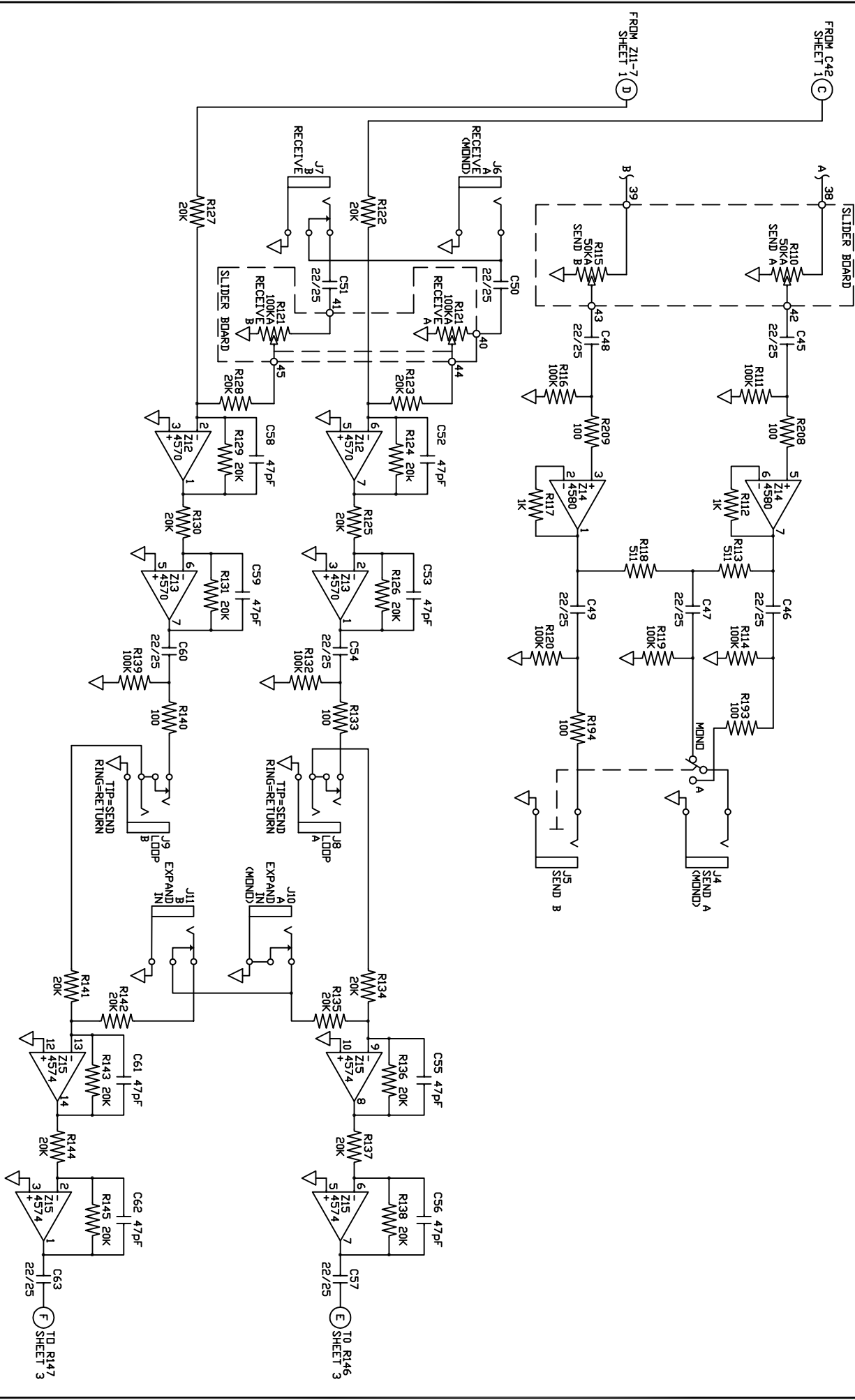

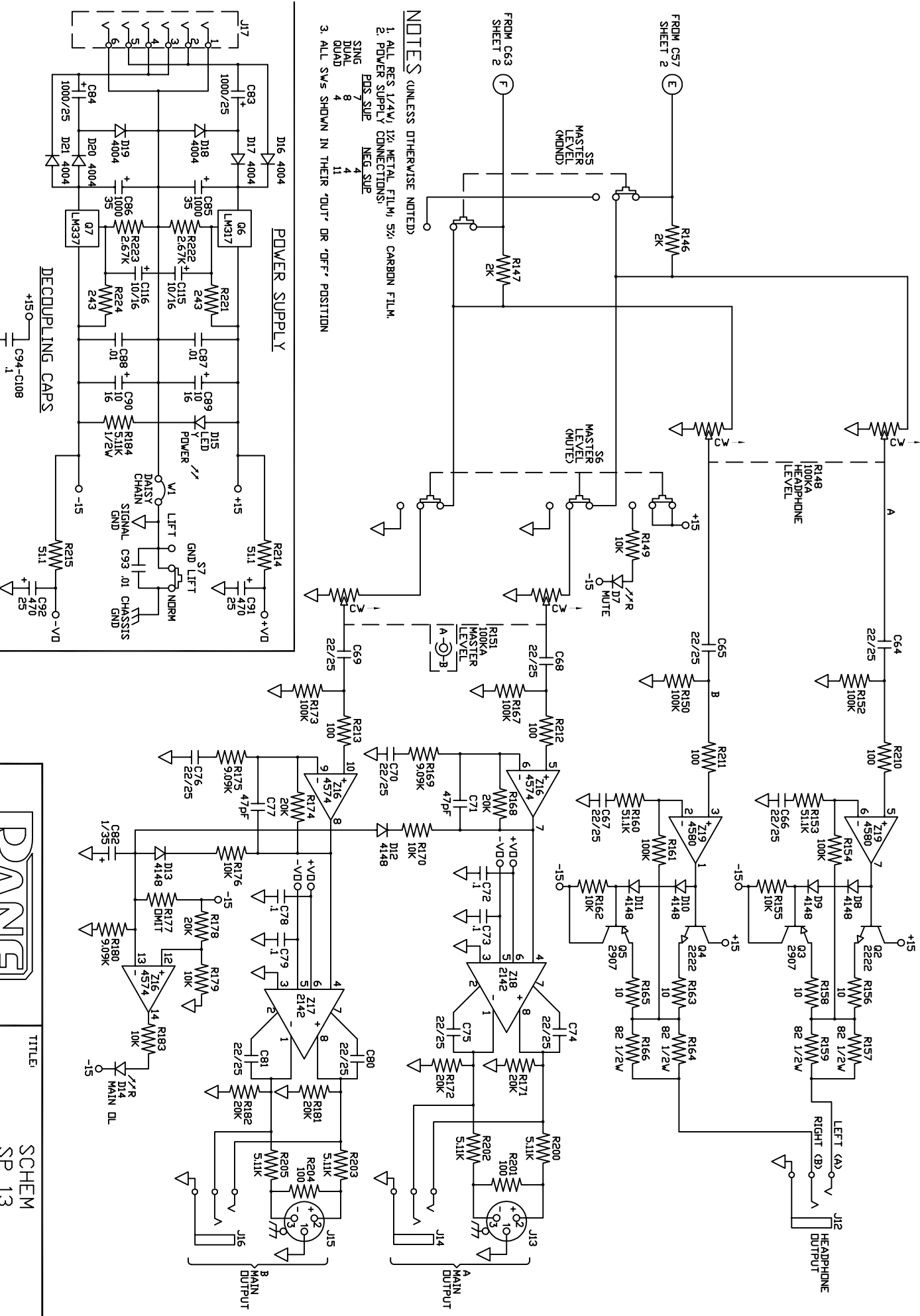

NOTES (UNLESS OTHERWISE NOTED)

1. ALL RES 1/4W, 1% METAL FILM, 5% CARBON FILM.
2. POWER SUPPLY CONNECTIONS.
3. ALL SWS SHOWN IN THEIR 'OUT' OR 'OFF' POSITION.